

For Sale

DOYLE

STRUCTURAL SOLUTIONS LLC
STEEL FABRICATING MACHINERY

For Sale



2013 PEDDINGHAUS 643Q Anglemaster



Anglemaster Capabilities

- Punching
- Shearing
- Scribing
- Hard Stamping



Acceptable Material Dimensions:

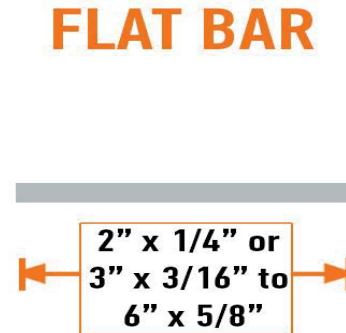
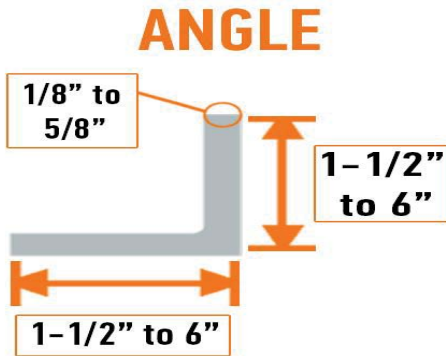

Punch Specifications:

Capacity	75 Tons
Maximum Hole Size 271/272 Tooling	1-1/4"
Maximum Hole Size 282 Tooling	1-1/2"
Maximum Hole Size PFP #3 Tooling	1-1/16"

Shear Specifications:

Single Cut Shear Tonnage	230 Tons
Type of Shear Blade	Single Cut (Double Cut by request)
Optional Double Cut Shear Tonnage	100 tons

Machine accuracy is +/- .04" per 32.8' material travel in the "X" axis, and +/- .03" in the "W", "Y" and "Z" axes.

For more information on this special offer contact:

DOYLE STRUCTURAL SOLUTIONS

Phone: 570-369-5700 Email:

Machines@DoyleStructuralSolutions.com

\$149,900.00

AS IS WHERE IS

Terms: 1/3 Cash with order; balance before shipment. Guarantee: Machines are sold with the understanding that, if not as represented, they may be returned, freight prepaid, within 30 days with full refund. This does not apply to machines sold "AS IS" Doyle Structural Solutions makes no warranty of merchantability or of fitness for purpose. Safety: This machine may or may not conform to the current OSHA Standards and other applicable safety regulations. It is the responsibility of the Buyer & User to provide proper safety equipment and devices to protect the operator from harm for any particular use or set-up, and to adequately safeguard and equip the machine to comply with all applicable safety standards. Indemnification: Buyer/User agrees to indemnify and hold harmless Seller from any and all claims and liabilities due to accidents caused by failure of Buyer/User, his employees or agents, to follow proper safety instructions or procedures when operating machine, or from failure of Buyer/User to comply with applicable safety standards. Applicable Law: The contract resulting from the acceptance of an order pursuant to this quotation shall be governed by the laws of the Commonwealth of Pennsylvania.